

NAME OF THE MEDICINAL PRODUCT

Tradename

RISPERDAL[®] CONSTA[®]

International Non-Proprietary Name

Risperidone

QUALITATIVE AND QUANTITATIVE COMPOSITION

RISPERDAL[®] CONSTA[®] contains 25 mg, 37.5 mg or 50 mg risperidone.

RISPERDAL[®] CONSTA[®] is an extended release microspheres formulation of risperidone, composed of risperidone drug substance micro-encapsulated in polylactide-co-glycolide, at a concentration of 381 mg risperidone per gram of microspheres.

For excipients, see List of Excipients.

PHARMACEUTICAL FORM

Prolonged-release powder and diluent for suspension for injection.

Vial With Powder.

White to off-white free flowing powder.

Pre-Filled Syringe of Diluent for Reconstitution.

Clear, colorless aqueous solution.

CLINICAL PARTICULARS

Therapeutic Indications

RISPERDAL[®] CONSTA[®] is indicated for the treatment of schizophrenia and schizoaffective disorder.

Posology and Method of Administration

For risperidone naive patients, it is recommended to establish tolerability with oral risperidone prior to initiating treatment with RISPERDAL[®] CONSTA[®].

RISPERDAL[®] CONSTA[®] should be administered every two weeks by deep intramuscular deltoid or gluteal injection using the appropriate safety needle. For deltoid administration, use the 1-inch needle alternating injections between the two arms. For gluteal administration, use the 2-inch needle alternating injections between the two buttocks. Do not administer intravenously (see Special Warnings and Special Precautions for Use – Administration and Instructions for Use).

Adults

The recommended dose is 25 mg intramuscular every two weeks. Some patients may benefit from the higher doses of 37.5 mg or 50 mg. No additional benefit was observed with 75 mg in clinical trials in patients with schizophrenia. Doses higher than 50 mg every 2 weeks are not recommended.

Sufficient antipsychotic coverage should be ensured during the three-week lag period following the first RISPERDAL[®] CONSTA[®] injection (see Pharmacokinetic Properties).

Upward dosage adjustment should not be made more frequently than every 4 weeks. The effect of this dose adjustment should not be anticipated earlier than 3 weeks after the first injection with the higher dose.

Elderly

The recommended dose is 25 mg intramuscular every two weeks. Sufficient antipsychotic coverage should be ensured during the three-week lag period following

the first RISPERDAL[®] CONSTA[®] injection (see Pharmacokinetic Properties).

Hepatic and Renal Impairment

RISPERDAL[®] CONSTA[®] has not been studied in hepatically and renally impaired patients.

If hepatically or renally impaired patients require treatment with RISPERDAL[®] CONSTA[®], a starting dose of 0.5 mg twice daily oral risperidone is recommended during the first week. The second week 1 mg twice daily or 2 mg once daily can be given. If an oral total daily dose of at least 2 mg is well tolerated, an injection of 25 mg RISPERDAL[®] CONSTA[®] can be administered every 2 weeks.

Children

RISPERDAL[®] CONSTA[®] has not been studied in children younger than 18 years.

Contraindications

RISPERDAL[®] CONSTA[®] is contraindicated in patients with a known hypersensitivity to the product or any of the components.

Special Warnings and Special Precautions for Use

For risperidone naive patients, it is recommended to establish tolerability with oral risperidone prior to initiating treatment with RISPERDAL[®] CONSTA[®].

Elderly Patients With Dementia

Overall Mortality

Elderly patients with dementia treated with atypical antipsychotic drugs have an increased mortality compared to placebo in a meta-analysis of 17 controlled trials of atypical antipsychotic drugs, including RISPERDAL[®]. In placebo-controlled trials with oral RISPERDAL[®] in this population, the incidence of mortality was 4.0% for RISPERDAL[®]-treated patients compared to 3.1% for placebo-treated patients. The mean age (range) of patients who died was 86 years (range 67-100).

Concomitant Use With Furosemide

In the oral RISPERDAL[®] placebo-controlled trials in elderly patients with dementia, a higher incidence of mortality was observed in patients treated with furosemide plus risperidone (7.3%; mean age 89 years, range 75-97) when compared to patients treated with risperidone alone (3.1%; mean age 84 years, range 70-96) or furosemide alone (4.1%; mean age 80 years, range 67-90). The increase in mortality in patients treated with furosemide plus risperidone was observed in two of the four clinical trials.

No pathophysiological mechanism has been identified to explain this finding, and no consistent pattern for cause of death observed. Nevertheless, caution should be exercised and the risks and benefits of this combination should be considered prior to the decision to use. There was no increased incidence of mortality among patients taking other diuretics as concomitant medication with risperidone. Irrespective of treatment, dehydration was an overall risk factor for mortality and should therefore be carefully avoided in elderly patients with dementia.

Cerebrovascular Adverse Events (CAE)

In placebo-controlled trials in elderly patients with dementia, there was a higher incidence of cerebrovascular adverse events (cerebrovascular accidents and transient ischemic attacks), including fatalities in patients (mean age 85 years; range 73-97) treated with oral RISPERDAL[®] compared to patients receiving placebo.

Orthostatic Hypotension

Due to the alpha-blocking activity of risperidone, (orthostatic) hypotension can occur, especially during initiation of treatment. Clinically significant hypotension has been

observed postmarketing with concomitant use of risperidone and antihypertensive treatment. Risperidone should be used with caution in patients with known cardiovascular disease (e.g. heart failure, myocardial infarction, conduction abnormalities, dehydration, hypovolemia, or cerebrovascular disease). The risk/benefit of further treatment with RISPERDAL[®] CONSTA[®] should be assessed if clinically relevant orthostatic hypotension persists.

Leukopenia, Neutropenia, and Agranulocytosis

Events of leukopenia, neutropenia and agranulocytosis have been reported with antipsychotic agents, including RISPERDAL[®] CONSTA[®]. Agranulocytosis has been reported very rarely (< 1/10000 patients) during post-marketing surveillance.

Patients with a history of a clinically significant low white blood cell count (WBC) or a drug-induced leukopenia/neutropenia should be monitored during the first few months of therapy and discontinuation of RISPERDAL[®] CONSTA[®] should be considered at the first sign of a clinically significant decline in WBC in the absence of other causative factors.

Patients with clinically significant neutropenia should be carefully monitored for fever or other symptoms or signs of infection and treated promptly if such symptoms or signs occur. Patients with severe neutropenia (absolute neutrophil count < 1 X 10⁹/L) should discontinue RISPERDAL[®] CONSTA[®] and have their WBC followed until recovery.

Venous thromboembolism

Cases of venous thromboembolism (VTE) have been reported with antipsychotic drugs. Since patients treated with antipsychotics often present with acquired risk factors for VTE, all possible risk factors for VTE should be identified before and during treatment with RISPERDAL[®] CONSTA[®] and preventive measures undertaken.

Tardive Dyskinesia/Extrapyramidal Symptoms (TD/EPS)

Drugs with dopamine receptor antagonistic properties have been associated with the induction of tardive dyskinesia characterized by rhythmic involuntary movements, predominantly of the tongue and/or face. It has been reported that the occurrence of extrapyramidal symptoms is a risk factor for the development of tardive dyskinesia. Because risperidone has a lower potential to induce extrapyramidal symptoms than classical neuroleptics, it should have a reduced risk of inducing tardive dyskinesia as compared to classical neuroleptics. If signs and symptoms of tardive dyskinesia appear, the discontinuation of all antipsychotic drugs should be considered.

Neuroleptic Malignant Syndrome (NMS)

Neuroleptic Malignant Syndrome, characterized by hyperthermia, muscle rigidity, autonomic instability, altered consciousness and elevated serum creatine phosphokinase levels has been reported to occur in association with antipsychotics. Additional signs may include myoglobinuria (rhabdomyolysis) and acute renal failure. In this event, all antipsychotic drugs, including risperidone, should be discontinued. After the last administration of RISPERDAL[®] CONSTA[®], plasma levels of risperidone are present for up to (a minimum of) 6 weeks.

Parkinson's Disease and Dementia with Lewy Bodies

Physicians should weigh the risks versus the benefits when prescribing antipsychotics, including RISPERDAL[®] CONSTA[®], to patients with Parkinson's Disease or Dementia with Lewy Bodies (DLB) since both groups may be at increased risk of Neuroleptic Malignant Syndrome as well as having an increased sensitivity to antipsychotic medications. Manifestation of this increased sensitivity can include

confusion, obtundation, postural instability with frequent falls, in addition to extrapyramidal symptoms.

Hyperglycemia and Diabetes Mellitus

Hyperglycemia, diabetes mellitus and exacerbation of pre-existing diabetes have been reported during treatment with RISPERDAL[®]. Assessment of the relationship between atypical antipsychotic use and glucose abnormalities is complicated by the possibility of an increased background risk of diabetes mellitus in patients with schizophrenia and the increasing incidence of diabetes mellitus in the general population. Given these confounders, the relationship between atypical antipsychotic use and hyperglycemia-related adverse events is not completely understood. Any patient treated with atypical antipsychotics, including RISPERDAL[®] CONSTA[®] should be monitored for symptoms of hyperglycemia and diabetes mellitus. (see also Undesirable Effects).

Weight Gain

Significant weight gain has been reported. Monitoring weight gain is advisable when RISPERDAL[®] CONSTA[®] is being used

QT Interval

As with other antipsychotics, caution should be exercised when RISPERDAL[®] CONSTA[®] is prescribed in patients with a history of cardiac arrhythmias, in patients with congenital long QT syndrome, and in concomitant use with drugs known to prolong the QT interval.

Priapism

Drugs with alpha-adrenergic blocking effects have been reported to induce priapism. Priapism has been reported with RISPERDAL[®] during postmarketing surveillance (see Undesirable Effects).

Body Temperature Regulation

Disruption of the body's ability to reduce core body temperature has been attributed to antipsychotic agents. Appropriate care is advised when prescribing RISPERDAL[®] CONSTA[®] to patients who will be experiencing conditions which may contribute to an elevation in core body temperature, e.g., exercising strenuously, exposure to extreme heat, receiving concomitant medication with anticholinergic activity, or being subject to dehydration.

Antiemetic Effect

An antiemetic effect was observed in preclinical studies with risperidone. This effect, if it occurs in humans, may mask the signs and symptoms of overdose with certain drugs or of conditions such as intestinal obstruction, Reye's syndrome, and brain tumor.

Seizures

As with other antipsychotic drugs, RISPERDAL[®] CONSTA[®] should be used cautiously in patients with a history of seizures or other conditions that potentially lower the seizure threshold.

Administration

Care must be taken to avoid inadvertent injection of RISPERDAL[®] CONSTA[®] into a blood vessel (see Undesirable Effects [retinal artery occlusion]).

Interactions with Other Medicinal Products and Other Forms of Interaction

Given the primary CNS effects of risperidone it should be used with caution in combination with other centrally acting drugs.

Risperidone may antagonize the effect of levodopa and other dopamine agonists.

Clinically significant hypotension has been observed postmarketing with concomitant use of risperidone and antihypertensive treatment.

Caution is advised when prescribing RISPERSDAL[®] CONSTA[®] with drugs known to prolong the QT interval.

Carbamazepine has been shown to decrease the plasma concentrations of the active antipsychotic fraction of risperidone. Similar effects may be observed with other CYP 3A4 hepatic enzyme inducers. When carbamazepine or other CYP 3A4 hepatic enzyme inducers are initiated or discontinued, the physician should re-evaluate the dosing of RISPERSDAL[®] CONSTA[®].

Fluoxetine and paroxetine, CYP 2D6 inhibitors, increase the plasma concentration of risperidone but less so of the active antipsychotic fraction. When concomitant fluoxetine or paroxetine is initiated or discontinued, the physician should re-evaluate the dosing of RISPERSDAL[®] CONSTA[®].

Topiramate modestly reduced the bioavailability of risperidone, but not that of the active antipsychotic fraction. Therefore, this interaction is unlikely to be of clinical significance.

Phenothiazines, tricyclic antidepressants and some beta-blockers may increase the plasma concentrations of risperidone but not those of the active antipsychotic fraction. Amytriptyline does not affect the pharmacokinetics of risperidone or the active antipsychotic fraction. Cimetidine and ranitidine increased the bioavailability of risperidone, but only marginally that of the active antipsychotic fraction. Erythromycin, a CYP 3A4 inhibitor, does not change the pharmacokinetics of risperidone and the active antipsychotic fraction. The cholinesterase inhibitors, galantamine and donepezil, do not show a clinically relevant effect on the pharmacokinetics of risperidone and the active antipsychotic fraction. When risperidone is taken together with other highly protein-bound drugs, there is no clinically relevant displacement of either drug from the plasma proteins.

Risperidone does not show a clinically relevant effect on the pharmacokinetics of lithium, valproate, digoxin, or topiramate.

See Special Warnings and Special Precautions for Use regarding increased mortality in elderly patients with dementia concomitantly receiving furosemide and oral RISPERSDAL[®].

Pregnancy and Lactation

Use during pregnancy

The safety of risperidone for use during human pregnancy has not been established. Although, in experimental animals, risperidone did not show direct reproductive toxicity, some indirect, prolactin- and CNS-mediated effects were observed. No teratogenic effect of risperidone was noted in any study. Neonates exposed to antipsychotic drugs (including RISPERSDAL[®]) during the third trimester of pregnancy are at risk for extrapyramidal and/or withdrawal symptoms that may vary in severity following delivery. These symptoms in the neonates may include agitation, hypertonia, hypotonia, tremor, somnolence, respiratory distress, or feeding disorder.

RISPERSDAL[®] CONSTA[®] should only be used during pregnancy if the benefits outweigh the risks.

Use during lactation

In animal studies, risperidone and 9-hydroxy-risperidone are excreted in the milk. It has been demonstrated that risperidone and 9-hydroxy-risperidone are also excreted

in human breast milk. Therefore, women receiving RISPERDAL[®] CONSTA[®] should not breast-feed.

Effects on Ability to Drive and Use Machines

Risperidone may interfere with activities requiring mental alertness. Therefore, patients should be advised not to drive or operate machinery until their individual susceptibility is known.

Undesirable Effects

Clinical Trial Data

The safety of RISPERDAL[®] CONSTA[®] was evaluated from a clinical trial database consisting of 2392 patients exposed to one or more doses of RISPERDAL[®] CONSTA[®] for the treatment of schizophrenia. Of these 2392 patients, 332 were patients who received RISPERDAL[®] CONSTA[®] while participating in a 12-week double-blind, placebo-controlled trial. A total of 202 of the 332 were schizophrenic patients who received 25 mg or 50 mg RISPERDAL[®] CONSTA[®]. The conditions and duration of treatment with RISPERDAL[®] CONSTA[®] varied greatly and included (in overlapping categories) double-blind, fixed- and flexible-dose, placebo- or active-controlled studies and open-label phases of studies, inpatients and outpatients, and short-term (up to 12 weeks) and longer-term (up to 4 years) exposures.

The majority of all adverse reactions were mild to moderate in severity.

Double-Blind, Placebo-Controlled Data – Schizophrenia

Adverse drug reactions (ADRs) reported by ≥ 2% of RISPERDAL[®] CONSTA[®]-treated patients with schizophrenia in one 12-week double-blind, placebo-controlled trial are shown in Table 1.

Table 1. Adverse Drug Reactions Reported by ≥ 2% of RISPERDAL[®] CONSTA[®]-Treated Patients with Schizophrenia in a 12-Week Double-Blind, Placebo-Controlled Trial

System/Organ Class Adverse Reaction	RISPERDAL [®] CONSTA [®] 25 mg (n=99) %	RISPERDAL [®] CONSTA [®] 50 mg (n=103) %	Placebo (n=98) %
Infections and Infestations			
Upper respiratory tract infection	2	0	1
Nervous System Disorders			
Headache	15	21	12
Parkinsonism*	8	15	9
Dizziness	7	11	6
Akathisia*	4	11	6
	4	4	0
Somnolence	0	3	0
Tremor	2	2	3
Sedation	2	1	0
Syncope	2	0	0
Hypoaesthesia			
Eye Disorders			
Vision blurred	2	3	0

Table 1. Adverse Drug Reactions Reported by $\geq 2\%$ of RISPERDAL[®] CONSTA[®]-Treated Patients with Schizophrenia in a 12-Week Double-Blind, Placebo-Controlled Trial

System/Organ Class Adverse Reaction	RISPERDAL [®] CONSTA [®] 25 mg (n=99) %	RISPERDAL [®] CONSTA [®] 50 mg (n=103) %	Placebo (n=98) %
Respiratory, Thoracic and Mediastinal Disorders			
Cough	4	2	3
Sinus congestion	2	0	0
Gastrointestinal Disorders			
Constipation	5	7	1
Dry mouth	0	7	1
Dyspepsia	6	6	0
Nausea	3	4	5
Toothache	1	3	0
Salivary hypersecretion	4	1	0
Skin and Subcutaneous Tissue Disorders			
Acne	2	2	0
Dry skin	2	0	0
Musculoskeletal and Connective Tissue Disorders			
Pain in extremity	6	2	1
General Disorders and Administration Site Conditions			
Fatigue	3	6	0
Asthenia	0	3	0
Edema peripheral	2	3	1
Pain	4	1	0
Pyrexia	2	1	0
Investigations			
Weight increased	5	4	2
Weight decreased	4	1	1

* Parkinsonism includes extrapyramidal disorder, musculoskeletal stiffness, muscle rigidity, and bradykinesia. Akathisia includes akathisia and restlessness.

Other Clinical Trial Data

Paliperidone is the active metabolite of risperidone, therefore the adverse reaction profiles of these compounds (including both the oral and injectable formulations) are relevant to one another. This subsection includes additional ADRs reported with risperidone and/or paliperidone in clinical trials.

ADRs reported with risperidone and/or paliperidone by $\geq 2\%$ of RISPERDAL[®] CONSTA[®]-treated subjects with schizophrenia are shown in Table 2a.

Table 2a. ADRs Reported with Risperidone and/or Paliperidone by $\geq 2\%$ of RISPERDAL[®] CONSTA[®]-treated Subjects with Schizophrenia (The Terms within each System Organ Class are Sorted Alphabetically)

System/Organ Class
Adverse Reaction

System/Organ Class	Adverse Reaction
Psychiatric disorders	Agitation, Anxiety, Depression, Insomnia*
Nervous system disorders	Akathisia*, Parkinsonism*
Cardiac disorders	Tachycardia
Respiratory, thoracic and mediastinal disorders	Nasal congestion
Gastrointestinal disorders	Abdominal discomfort, Diarrhoea, Vomiting
Skin and subcutaneous tissue disorders	Rash
Musculoskeletal and Connective Tissue Disorders	Back pain, Muscle spasms, Musculoskeletal pain
General disorders and administration site conditions	Oedema*

* **Insomnia includes:** initial insomnia, middle insomnia; **Akathisia includes:** hyperkinesia, restless legs syndrome, restlessness; **Parkinsonism includes:** akinesia, bradykinesia, cogwheel rigidity, drooling, extrapyramidal symptoms, glabellar reflex abnormal, muscle rigidity, muscle tightness, musculoskeletal stiffness; Oedema includes: generalised oedema, oedema peripheral, pitting oedema. ADRs reported with risperidone and/or paliperidone by < 2% of RISPERDAL[®] CONSTA[®]-treated subjects with schizophrenia are shown in Table 2b.

Table 2b. ADRs Reported with Risperidone and/or Paliperidone by < 2% of RISPERDAL[®] CONSTA[®]-treated Subjects with Schizophrenia (The Terms within each System Organ Class are Sorted Alphabetically)

System/Organ Class	Adverse Reaction
Infections and infestations	Ear infection, Infection, Influenza, Sinusitis
Immune system disorders	Hypersensitivity
Metabolism and nutrition disorders	Decreased appetite, increased appetite
Psychiatric disorders	Confusional state, libido decreased, nightmare
Nervous system disorders	Dizziness postural, Dysarthria, Dyskinesia*, Paraesthesia
Eye disorders	Photophobia
Ear and labyrinth disorders	Ear pain

Cardiac disorders

Bradycardia, Conduction disorder, Electrocardiogram abnormal, Electrocardiogram QT prolonged, Palpitations

Respiratory, thoracic and mediastinal disorders

Dyspnoea, Pharyngolaryngeal pain, Wheezing

Hepatobiliary disorders

Gamma-glutamyltransferase increased, Hepatic enzyme increased

Skin and subcutaneous tissue disorders

Pruritus, Seborrhoeic dermatitis, Skin disorder

Musculoskeletal and connective tissue disorders

Joint stiffness, Muscular weakness

Renal and urinary disorders

Urinary incontinence

Reproductive system and breast disorders

Breast discomfort, Ejaculation disorder, Erectile dysfunction, Galactorrhoea

General disorders and administration site conditions

Chest discomfort, Feeling abnormal, Injection site reaction

* **Dyskinesia includes:** athetosis, chorea, choreoathetosis, movement disorder, muscle twitching, myoclonus

ADRs reported with risperidone and/or paliperidone in other clinical trials but not reported by RISPERDAL[®] CONSTA[®] (25 mg or 50 mg)-treated subjects with schizophrenia are shown in Table 2c.

Table 2c. ADRs Reported with Risperidone and/or Paliperidone in Other Clinical Trials but Not Reported by RISPERDAL[®] CONSTA[®] (25 mg or 50 mg)-treated subjects with schizophrenia. (The Terms within each System Organ Class are Sorted Alphabetically)

System/Organ Class

Adverse Reaction

Infections and Infestations

Acarodermatitis, Bronchitis, Cellulitis, Cystitis, Eye infection, Localised infection, Onychomycosis, Pneumonia, Respiratory tract infection, Subcutaneous abscess, Tonsillitis, Urinary tract infection, Viral infection

Blood and Lymphatic System Disorders

Anaemia, Eosinophil count increased, Haematocrit decreased, Neutropenia, White blood cell count decreased

Immune System Disorders

Anaphylactic reaction

Endocrine Disorders

Glucose urine present, Hyperprolactinaemia

Metabolism and Nutrition Disorders

Anorexia, Blood cholesterol increased, Blood triglycerides increased, Hyperglycaemia, Hyperinsulinaemia, Polydipsia

Psychiatric Disorders

Anorgasmia, Blunted affect, Sleep disorder

Nervous System Disorders

Balance disorder, Cerebrovascular accident, Cerebrovascular disorder, Convulsion*, Coordination abnormal, Depressed level of consciousness, Diabetic coma, Dystonia*, Head titubation, Loss of consciousness, Neuroleptic malignant syndrome, Psychomotor hyperactivity, Tardive dyskinesia, Unresponsive to stimuli

Eye Disorders

Conjunctivitis, Dry eye, Eye movement disorder, Eye rolling, Eyelid margin crusting, Glaucoma, Lacrimation increased, Ocular hyperaemia

Ear and Labyrinth Disorders

Tinnitus, Vertigo

Cardiac Disorders

Atrioventricular block, Postural orthostatic tachycardia syndrome, Sinus arrhythmia

Vascular Disorders

Flushing, Hypotension, Orthostatic hypotension

Respiratory, Thoracic and Mediastinal Disorders

Dysphonia, Epistaxis, Hyperventilation, Pneumonia aspiration, Pulmonary congestion, Rales, Respiratory disorder, Respiratory tract congestion

Gastrointestinal Disorders

Cheilitis, Dysphagia, Faecal incontinence, Faecaloma, Flatulence, Gastroenteritis, Intestinal obstruction, Swollen tongue

Hepatobiliary disorders

Transaminases increased

Skin and Subcutaneous Disorders

Drug eruption, Eczema, Erythema, Hyperkeratosis, Skin discolouration, Skin lesion, Urticaria

Musculoskeletal, Connective Tissue, and Bone Disorders

Blood creatine phosphokinase increased, Joint swelling, Neck pain, Posture abnormal, Rhabdomyolysis

Renal and Urinary Disorders

Dysuria, Pollakiuria

Reproductive System and Breast Disorders

Breast discharge, Breast engorgement, Breast enlargement, Gynaecomastia, Menstrual disorder*, Menstruation delayed, Sexual dysfunction, Vaginal discharge

General Disorders and Administration Site Conditions

Body temperature decreased, Body temperature increased, Chills, Discomfort, Drug withdrawal syndrome, Face oedema, Induration, Malaise, Peripheral coldness, Thirst

Injury, Poisoning and Procedural Complications

Fall, Procedural pain

* **Convulsion includes:** Grand mal convulsion; **Dystonia includes:** blepharospasm, cervical spasm, emprosthotonus, facial spasm, hypertonia, laryngospasm, muscle contractions involuntary, myotonia, oculogyration, opisthotonus, oropharyngeal spasm, pleurothotonus, risus sardonicus, tetany, tongue paralysis, tongue spasm, torticollis, trismus; **Menstrual disorder includes:** Menstruation irregular, Oligomenorrhoea

Postmarketing Data

Adverse events first identified as ADRs during postmarketing experience with risperidone and/or paliperidone are included in Table 3. In this table, the frequencies are provided according to the following convention:

Very common $\geq 1/10$
Common $\geq 1/100$ to $< 1/10$
Uncommon $\geq 1/1000$ to $< 1/100$
Rare $\geq 1/10000$ to $< 1/1000$
Very rare $< 1/10000$, including isolated reports

In Table 3, ADRs are presented by frequency category based on spontaneous reporting rates.

Table 3. Adverse Drug Reactions Identified During Postmarketing Experience with Risperidone and/or Paliperidone by Frequency Category Estimated from Spontaneous Reporting Rates with Risperidone

Blood and Lymphatic Disorders

Very rare Agranulocytosis, Thrombocytopenia

Endocrine Disorders

Very rare Inappropriate antidiuretic hormone secretion

Metabolism and Nutrition Disorders

Very rare Diabetes mellitus, Diabetic ketoacidosis, Hypoglycaemia, Water intoxication

Psychiatric Disorders

Very rare Mania

Nervous System Disorders

Very rare Dysgeusia

Eye Disorders

Very rare Retinal artery occlusion^a

Cardiac Disorders

Very rare Atrial fibrillation

Vascular Disorders

Very rare Deep vein thrombosis, Pulmonary embolism

Respiratory, Thoracic, and Mediastinal Disorders

Very rare Sleep apnoea syndrome

Gastrointestinal Disorders

Very rare Pancreatitis

Hepatobiliary Disorders

Very rare Jaundice

Skin and Subcutaneous Tissue Disorders

Very rare Alopecia, Angioedema

Table 3. Adverse Drug Reactions Identified During Postmarketing Experience with Risperidone and/or Paliperidone by Frequency Category Estimated from Spontaneous Reporting Rates with Risperidone

Renal and Urinary Disorders

Very rare Urinary retention

Pregnancy, Puerperium and Perinatal Conditions

Very rare Drug withdrawal syndrome neonatal

Reproductive System and Breast Disorders

Very rare Priapism

General Disorders

Very rare Hypothermia, Injection site abscess, Injection site cellulitis, Injection site cyst, Injection site haematoma, Injection site necrosis, Injection site ulcer

^a RISPERDAL[®] CONSTA[®] formulation only, reported in the presence of an intracardiac defect predisposing to a right-to-left shunt (e.g., a patent foramen ovale)

Overdose

While overdose is less likely to occur with parenteral than with oral medication, information pertaining to oral risperidone is presented.

Symptoms

In general, reported signs and symptoms have been those resulting from an exaggeration of the drug's known pharmacological effects. These include drowsiness and sedation, tachycardia and hypotension, and extrapyramidal symptoms. In overdose, QT-prolongation and convulsions have been reported. Torsade de pointes has been reported in association with combined overdose of oral RISPERDAL[®] and paroxetine.

In case of acute overdosage, the possibility of multiple drug involvement should be considered.

Treatment

Establish and maintain a clear airway and ensure adequate oxygenation and ventilation. Cardiovascular monitoring should commence immediately and should include continuous electrocardiographic monitoring to detect possible arrhythmias.

There is no specific antidote to RISPERDAL[®]. Therefore appropriate supportive measures should be instituted.

Hypotension and circulatory collapse should be treated with appropriate measures such as intravenous fluids and/or sympathomimetic agents. In case of severe extrapyramidal symptoms, anticholinergic medication should be administered. Close medical supervision and monitoring should continue until the patient recovers.

PHARMACOLOGICAL PROPERTIES

Pharmacodynamic Properties

Risperidone is a selective monoaminergic antagonist with unique properties. It has a high affinity for serotonergic 5-HT₂ and dopaminergic D₂ receptors. Risperidone binds also to alpha₁-adrenergic receptors, and, with lower affinity, to H₁-histaminergic and alpha₂-adrenergic receptors. Risperidone has no affinity for cholinergic receptors. Although risperidone is a potent D₂ antagonist, that is considered to improve the positive symptoms of schizophrenia, it causes less depression of motor activity and induction of catalepsy than classical neuroleptics. Balanced central serotonin and dopamine antagonism may reduce extrapyramidal side effect liability and extend the therapeutic activity to the negative and affective symptoms of schizophrenia.

Further Information on Clinical Trials

Schizophrenia

The effectiveness of RISPERDAL® CONSTA® (25 mg and 50 mg) in the management of the manifestations of psychotic disorders (schizophrenia/schizoaffective disorder) was established in one 12-week, placebo controlled trial in adult psychotic inpatients and outpatients who met the DSM-IV criteria for schizophrenia.

In a 12-week comparative trial in stable patients with schizophrenia, RISPERDAL® CONSTA® was shown to be as effective as the oral tablet formulation. The long-term (50 weeks) safety and efficacy of RISPERDAL® CONSTA® was also evaluated in an open-label trial of stable psychotic inpatients and outpatients who met the DSM-IV criteria for schizophrenia or schizoaffective disorder. Over time efficacy was maintained with RISPERDAL® CONSTA®.

Figure 1. Mean in total PANSS score over time (LOCF) in patients with schizophrenia.

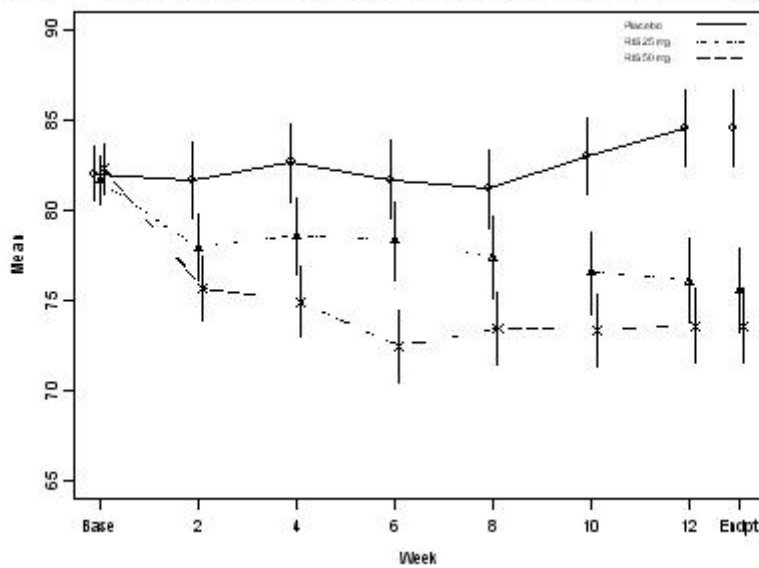
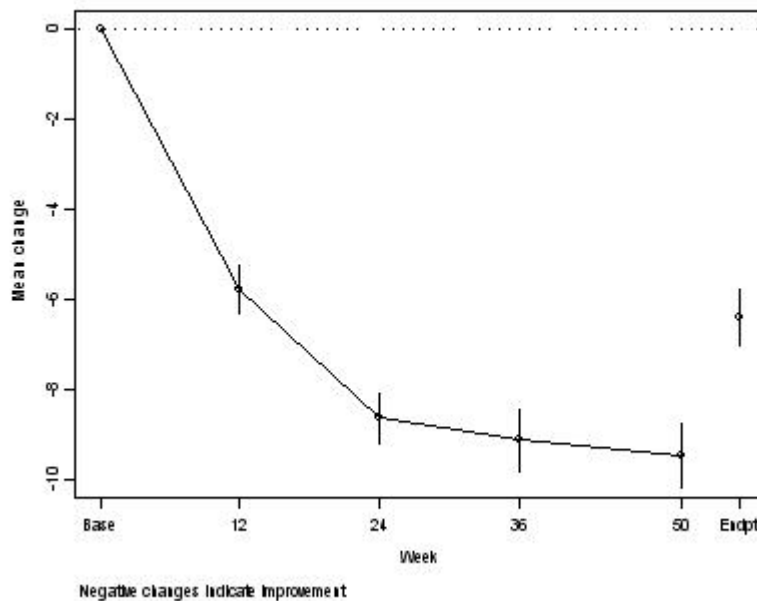

Figure 2. Mean change in total PANSS score from baseline for all doses tested in the 50-week, open-label trial.



Pharmacokinetic Properties

Risperidone is metabolised by CYP 2D6 to 9-hydroxy-risperidone which has a similar pharmacological activity as risperidone. Risperidone plus 9-hydroxy-risperidone form the active antipsychotic fraction. Another metabolic pathway of risperidone is N-dealkylation.

General characteristics of Risperidone after administration of RISPERDAL[®] CONSTA[®] in patients

After a single intramuscular injection with RISPERDAL[®] CONSTA[®], the release profile consists of a small initial release of drug (<1% of the dose), followed by a lag time of 3 weeks. The main release of drug starts from week 3 onwards, is maintained from 4 to 6 weeks, and subsides by week 7. Oral antipsychotic supplementation should therefore be given during the first 3 weeks of RISPERDAL[®] CONSTA[®] treatment (see Posology and Method of Administration).

The combination of the release profile and the dosage regimen (intramuscular injection every two weeks) results in sustained therapeutic plasma concentrations. Therapeutic plasma concentrations remain until 4 to 6 weeks after the last RISPERDAL[®] CONSTA[®] injection. The elimination phase is complete approximately 7 to 8 weeks after the last injection.

The absorption of risperidone from RISPERDAL[®] CONSTA[®] is complete.

Risperidone is rapidly distributed. The volume of distribution is 1-2 L/kg. In plasma, risperidone is bound to albumin and alpha-1-acid glycoprotein. The plasma protein binding of risperidone is 90%, the active metabolite 9-hydroxy-risperidone is 77%.

The active antipsychotic fraction and risperidone clearances were 5.0 and 13.7 L/h in extensive metabolizers, respectively, and 3.2 and 3.3 L/h in poor metabolizers of CYP 2D6, respectively.

After repeated intramuscular injections with 25 or 50 mg RISPERDAL[®] CONSTA[®] every two weeks, median trough and peak plasma concentrations of the active antipsychotic fraction fluctuated between 9.9-19.2 ng/ml and 17.9-45.5 ng/ml respectively. The pharmacokinetics of risperidone are linear in the dose range of 25-50 mg injected every 2 weeks. No accumulation of risperidone was observed during long term use (12 months) in patients who were injected with 25–50 mg every two weeks.

The above studies were conducted with gluteal intramuscular injection. Deltoid and gluteal intramuscular injections at the same doses are bioequivalent and, therefore, interchangeable.

A single-dose study with oral risperidone showed higher active plasma concentrations and a reduced clearance of the active antipsychotic fraction by 30% in the elderly and 60% in patients with renal insufficiency. Risperidone plasma concentrations were normal in patients with liver insufficiency, but the mean free fraction of risperidone in plasma was increased by about 35%.

Pharmacokinetic/Pharmacodynamic Relationship

There was no relationship between the plasma concentrations of the active antipsychotic fraction and the change in total PANSS (Positive and Negative Syndrome Scale) and total ESRS (Extrapyramidal Symptom Rating Scale) scores across the assessment visits in any of the phase-III trials where efficacy and safety was examined.

Preclinical Safety Data

Similar to the (sub)chronic toxicity studies with oral risperidone in rats and dogs, the major effects of treatment with RISPERDAL[®] CONSTA[®] (up to 12 months of RISPERDAL[®] CONSTA[®] ALARIS (Alaris (gluteal and deltoid)), [08-July-2011], [Version #019]

intramuscular administration) were prolactin-mediated mammary gland stimulation, male and female genital tract changes, and central nervous system (CNS) effects, related to the pharmacodynamic activity of risperidone. In an oral toxicity study with juvenile rats, increased pup mortality and a delay in physical development was observed. In a 40-week study with juvenile dogs treated with oral risperidone, sexual maturation was delayed. Long bone growth was not affected at a dose similar to the maximum human oral dose in adolescents (6 mg/day); effects were observed at a dose 4-fold (on an AUC basis) or 7-fold (on a mg/m² basis) the maximum human oral dose in adolescents.

RISPERDAL[®] CONSTA[®] administration to male and female rats for 12 and 24 months produced osteodystrophy at a dose of 40 mg/kg/2 weeks. The effect dose for osteodystrophy in rats was on a mg/m² basis 8 times the maximum recommended human dose and is associated with a plasma exposure 2 times the maximum anticipated exposure in humans at the maximum recommended dose. No osteodystrophy was observed in dogs treated for 12 months with RISPERDAL[®] CONSTA[®] up to 20 mg/kg/2 weeks. This dose yielded plasma exposures up to 14 times the maximum recommended human dose.

There was no evidence of mutagenic potential.

As expected for a potent dopamine D₂-antagonist, in an intramuscular carcinogenicity study in Wistar (Hannover) rats (doses of 5 and 40 mg/kg/2 weeks), prolactin-mediated increased incidences of endocrine pancreas, pituitary gland, and adrenal medullary tumors were observed at 40 mg/kg, while mammary gland tumors were present at 5 and 40 mg/kg. Hypercalcemia, postulated to contribute to an increased incidence of adrenal medullary tumors, was observed in both dose groups. There is no evidence to suggest that hypercalcemia might cause pheochromocytomas in humans.

Renal tubular adenomas occurred in male rats at 40 mg/kg/2 weeks. No renal tumors occurred in the low dose, the NaCl 0.9%, or the microspheres vehicle control group. The mechanism underlying the renal tumors in RISPERDAL[®] CONSTA[®] treated male Wistar (Hannover) rats is unknown. A treatment-related increase in renal tumor incidence did not occur in the oral carcinogenicity studies with Wistar (Wiga) rats or in Swiss mice administered oral risperidone. Studies conducted to explore the substrain differences in the tumor organ profile suggest that the Wistar (Hannover) substrain employed in the carcinogenicity study differs substantially from the Wistar (Wiga) substrain employed in the oral carcinogenicity study with respect to spontaneous age-related non-neoplastic renal changes, serum prolactin increases, and renal changes in response to risperidone. There are no data suggesting kidney-related changes in dogs treated chronically with RISPERDAL[®] CONSTA[®]. The relevance of the osteodystrophy, the prolactin-mediated tumors and of the presumed rat substrain-specific renal tumors in terms of human risk is unknown.

Local irritation at the injection site in dogs and rats was observed after administration of high doses of RISPERDAL[®] CONSTA[®]. In a 24-month IM carcinogenicity study in rats, no increased incidence of injection site tumors was seen in either the vehicle or the active drug groups.

PHARMACEUTICAL PARTICULARS

List of Excipients

RISPERDAL[®] CONSTA[®]

7525 DL JN1 [poly-(d,l-lactide-co-glycolide)] polymer

Diluent

RISPERDAL[®] CONSTA[®] ALARIS (Alaris (gluteal and deltoid)), [08-July-2011], [Version #019]

Polysorbate 20, carmellose sodium 40mPa.s, disodium hydrogen phosphate dihydrate, citric acid anhydrous, sodium chloride, sodium hydroxide, water for injection.

Incompatibilities

RISPERDAL[®] CONSTA[®] cannot be mixed or diluted with drugs or fluids other than the supplied diluent for administration.

Shelf Life

Observe expiry date on the outer carton pack.

After reconstitution: Chemical and physical in-use stability has been demonstrated for 24 hours at 25°C. From a microbiological point of view, the product should be used immediately. If not used immediately, in-use storage times and conditions prior to use are the responsibility of the user and would normally not be longer than 6 hours at 25°C, unless reconstitution has taken place in controlled and validated aseptic conditions.

Special Precautions for Storage

The entire dose pack should be stored in the refrigerator (2-8°C) and protected from light. It should not be exposed to temperatures above 25°C.

If refrigeration is unavailable, RISPERDAL[®] CONSTA[®] can be stored at temperatures not exceeding 25°C for no more than 7 days prior to administration. Do not expose unrefrigerated product to temperatures above 25°C.

Keep out of reach of children.

Nature and Contents of Container

RISPERDAL[®] CONSTA[®] will be packaged in the following container/closure configuration:

Needle-Free Vial Access Device

- One vial containing RISPERDAL[®] CONSTA[®] extended release microspheres.
- One prefilled syringe containing the diluent for RISPERDAL[®] CONSTA[®].
- One Alaris[™] SmartSite[®] Needle-Free Vial Access Device for reconstitution.
- Two Needle-Pro[®] needles for intramuscular injection (a 21G UTW 1-inch safety needle with needle protection device for deltoid administration and a 20G TW 2-inch safety needle with needle protection device for gluteal administration). ("Rx - only" = device to be sold with Prescription Drugs only)

Instructions for Use and Handling and Disposal

Instruction for Needle-Free Vial Access Device

RISPERDAL[®] CONSTA[®] requires close attention to the step-by-step 'Instructions for Use' to help ensure successful administration and help avoid difficulties in the use of the kit.

RISPERDAL[®] CONSTA[®] extended release microspheres in the vial must be reconstituted **only** in the diluent in the syringe supplied in the dose pack and must be administered with **only** the appropriate needle supplied in the dose pack for gluteal (2-inch needle) or deltoid (1-inch needle) administration. Do not substitute any components in the dose pack. To assure that the intended dose of risperidone is delivered, the full contents from the vial must be administered. Administration of partial contents may not deliver the intended dose of risperidone. It is recommended to administer immediately after reconstitution.

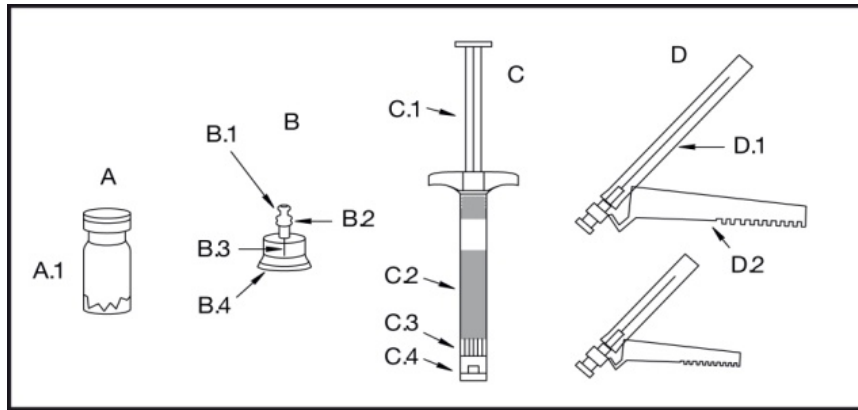

A-Vial; A.1-Colored cap; B-Vial access device; B.1-White luer connection point; B.2-Luer cap; B.3-Spike tip; B.4-Skirt; C-Prefilled Syringe; C.1-Plunger rod; C.2-Diluent; C.3-White collar; C.4-White cap; D-Needle-Pro[®] Needle for I.M. Injection; D.1-Transparent needle sheath; D.2- Orange needle protection device

Remove the dose pack of RISPERDAL[®] CONSTA[®] from the refrigerator and allow it to come to room temperature for approximately 30 minutes prior to reconstitution. Contents of the dose pack:

- One vial containing RISPERDAL[®] CONSTA[®] extended release microspheres
 - One Alaris[™] SmartSite[®] Needle-Free Vial Access Device for reconstitution
 - One prefilled syringe containing the diluent for RISPERDAL[®] CONSTA[®]
 - Two needles for intramuscular injection (a 21G UTW 1-inch safety needle with Needle-Pro[®] safety device for deltoid administration and a 20G TW 2-inch safety needle with Needle-Pro[®] safety device for gluteal administration)
1. Flip off the plastic colored cap from the vial. Do not remove the grey rubber stopper. Wipe the top of the grey rubber stopper with an alcohol wipe and allow to dry.

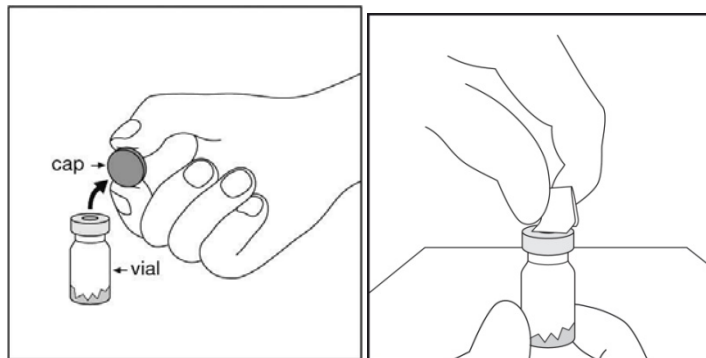

2. Peel back the blister pouch and remove the SmartSite[®] Needle-Free Vial Access Device by holding between the white luer cap and the skirt. *Do not touch the spike tip of the access device at any time.*

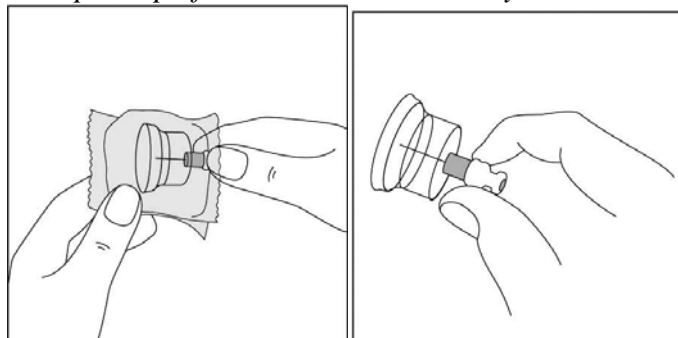

3. **It is very important that the SmartSite[®] Needle-Free Vial Access Device be placed on the vial correctly or the diluent could leak upon transfer to the vial.**

Place the vial on a hard surface. Hold the base of the vial. Orient the SmartSite[®] Needle-Free Vial Access Device vertically over the vial so that the spike tip is at the center of the vial's rubber stopper.

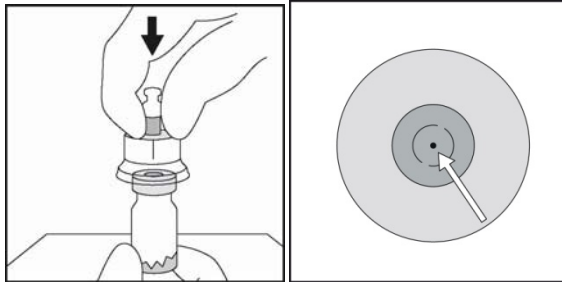

With a straight downward push press the spike tip of the SmartSite[®] Needle-Free Vial Access Device through the center of the vial's rubber stopper until the device securely snaps onto the vial top.

Correct

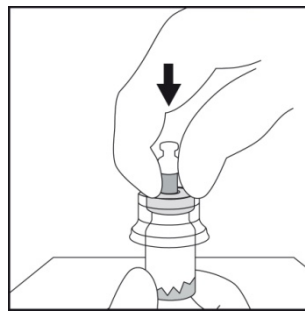

Incorrect

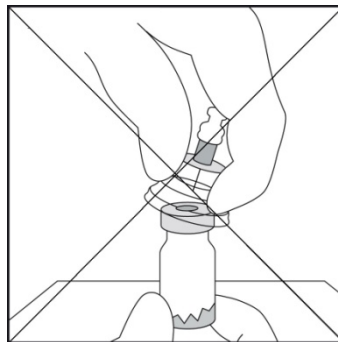

4. **Hold the base of the vial** and swab the syringe connection point (blue circle) of SmartSite[®] Needle-Free Vial Access Device with an alcohol wipe and allow to dry prior to attaching the syringe to the SmartSite[®] Needle-Free Vial Access Device.

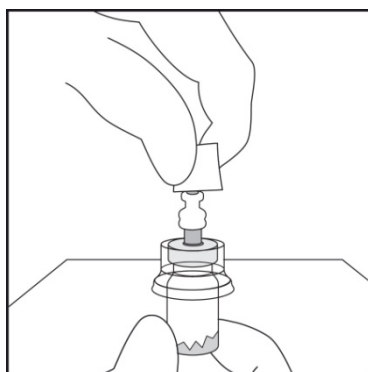

5. The prefilled syringe has a white tip consisting of 2 parts: a white collar and a smooth white cap. To open the syringe, hold the syringe by the white collar and **snap** off the smooth white cap (**DO NOT TWIST OR CUT OFF THE WHITE CAP**). Remove the white cap together with the rubber tip cap inside.

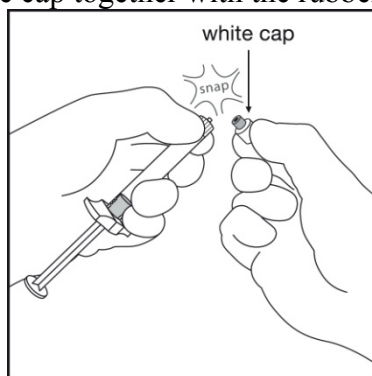

For all syringe assembly steps, hold the syringe only by the white collar located at the tip of the syringe. **Holding the white collar will help to prevent the white collar from getting detached and ensure a good connection to the syringe.** Be careful not to overtighten components when assembling. Overtightening connections may cause syringe component parts to loosen from the syringe body.

6. While holding the **white collar** of the syringe, insert and **press** the syringe tip into the blue circle of SmartSite[®] Needle-Free Vial Access Device and **twist** in a clockwise motion to secure the connection of the syringe to SmartSite[®] Needle-Free Vial Access Device (avoid over-twisting).

Hold the skirt of the SmartSite[®] Needle-Free Vial Access Device during attachment to prevent it from spinning.

Keep the syringe and SmartSite[®] Needle-Free Vial Access Device aligned.

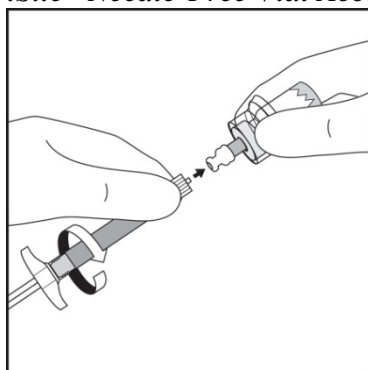

7. Inject the entire contents of the syringe containing the diluent into the vial.

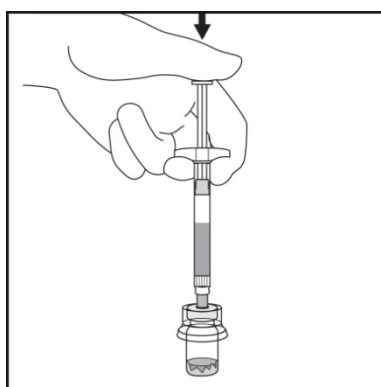

8. Shake the vial **VIGOROUSLY** while holding the plunger rod down with the thumb for a minimum of 10 seconds to ensure a homogeneous suspension. When properly mixed, the suspension appears uniform, thick, and milky in color. The microspheres will be visible in liquid, but no dry microspheres remain.

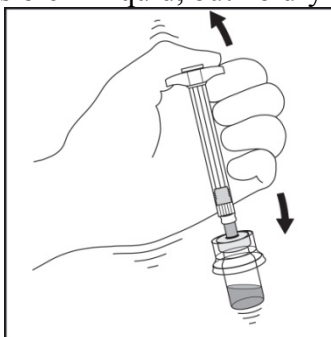

DO NOT STORE THE VIAL AFTER RECONSTITUTION OR THE SUSPENSION MAY SETTLE.

9. Invert the vial completely and **SLOWLY** withdraw the entire contents of the suspension from the vial into the syringe. Tear the section of the vial label at the perforation and apply the detached label to the syringe for identification purposes.

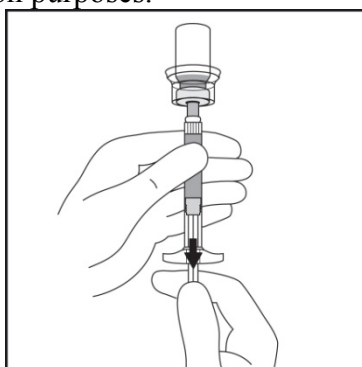

10. While holding the **white collar** of the syringe, unscrew the syringe from the SmartSite[®] Needle-Free Vial Access Device. Discard both the vial and vial access device appropriately.

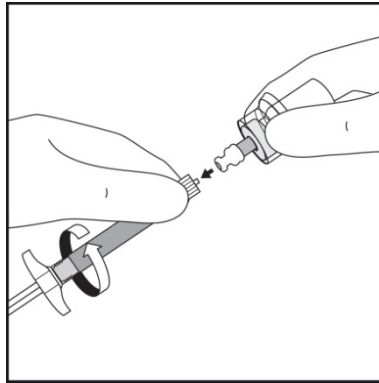

11. Open the needle pack and select the appropriate needle provided with the kit. Do NOT touch the connection part of the needle, only touch the transparent sheath of the needle:

For GLUTEAL injection, select the **20G TW 2-inch** needle (longer needle with **yellow** colored hub).

For DELTOID injection, select the **21G UTW 1-inch** needle (shorter needle with **green** colored hub).

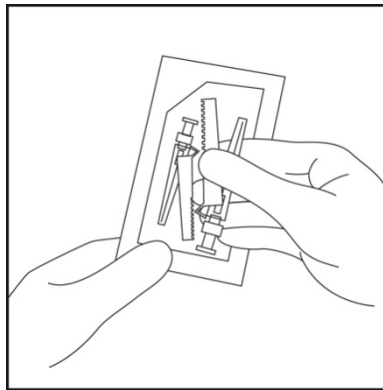

12. To prevent contamination, be careful not to touch the orange Needle-Pro[®] safety device's luer connector. While holding the **white collar** of the syringe, attach the luer connection of the orange Needle-Pro[®] safety device to the syringe with an easy clockwise twisting motion.

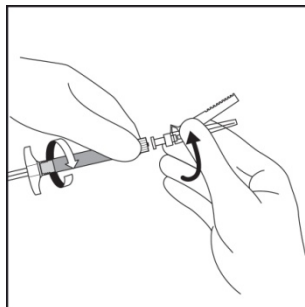

13. While continuing to hold the **white collar** of the syringe, grasp the transparent needle sheath and seat the needle firmly on the orange Needle-Pro[®] safety device with a push and a clockwise twist. **Seating the needle will help ensure a secure connection between the needle and the orange Needle-Pro[®] safety device while conducting the following steps.**

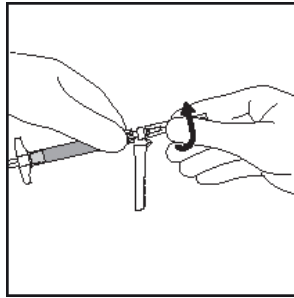

14. **RESUSPENSION OF RISPERDAL® CONSTA® WILL BE NECESSARY PRIOR TO ADMINISTRATION, AS SETTLING WILL OCCUR OVER TIME ONCE PRODUCT IS RECONSTITUTED. RESUSPEND THE MICROSPHERES IN THE SYRINGE BY SHAKING VIGOROUSLY.**

15. While holding the **white collar** of the syringe, pull the transparent needle sheath straight away from the needle. **DO NOT TWIST** the sheath as the luer connections may be loosened.

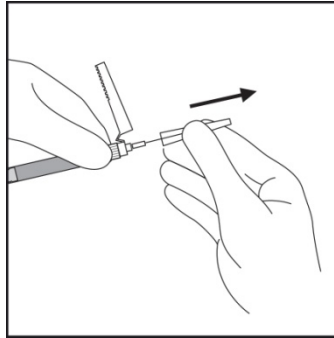

16. Tap the syringe gently to make any air bubbles rise to the top. Remove air in syringe by depressing the plunger rod, carefully and slowly, while holding the needle in an upright position. Inject the entire contents of the syringe intramuscularly into the selected gluteal or deltoid muscle of the patient immediately. Gluteal injection should be made into the upper-outer quadrant of the gluteal area.

DO NOT ADMINISTER INTRAVENOUSLY.

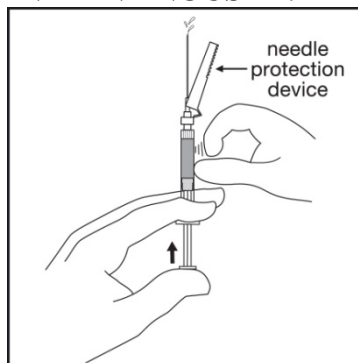

WARNING: To avoid a needle stick injury with a contaminated needle:

- Do not use free hand to press the Needle-Pro® safety device over the needle.
- Do not intentionally disengage the Needle-Pro® safety device
- Do not attempt to straighten the needle or engage Needle-Pro® safety device if the needle is bent or damaged
- Do not mishandle the Needle-Pro® safety device as it may cause the needle to protrude from the Needle-Pro® safety device.

17. After injection is complete, press the needle into the orange Needle-Pro[®] safety device using a one-handed technique. Perform a one-handed technique by GENTLY pressing the orange Needle-Pro[®] safety device against a flat surface. AS THE ORANGE NEEDLE-PRO[®] SAFETY DEVICE IS PRESSED, THE NEEDLE WILL FIRMLY ENGAGE INTO THE ORANGE NEEDLE-PRO[®] SAFETY DEVICE. Visually confirm that the needle is fully engaged into the orange Needle-Pro[®] safety device before discarding. Discard needle appropriately.

Also discard the other (unused) needle provided in the dose pack.

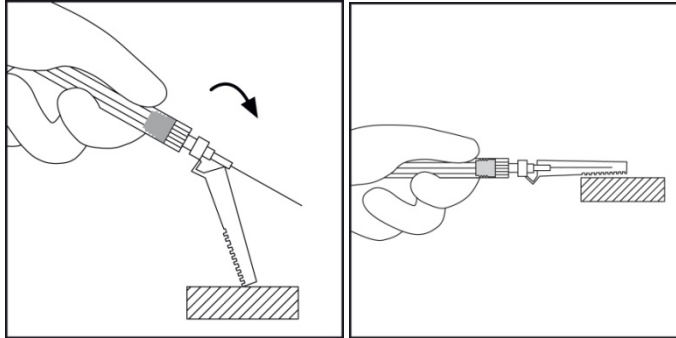

Do Not Reuse: Medical devices require specific material characteristics to perform as intended. These characteristics have been verified for single use only. Any attempt to re-process the device for subsequent re-use may adversely affect the integrity of the device or lead to deterioration in performance

DATE OF REVISION OF THE TEXT

July 2011